





scheda tecnica - data sheet



modello: model:	RACCORDI DI LUCE
codice: code:	3555
design:	Officina di Architettura e Design
anno - year:	2024
tipologia: typology:	lampada da terra IP65 IP65 floor lamp
materiali: materials:	acciaio INOX stainless steel
luce: light:	diretta direct
sorgente luminosa: light source:	/W LED 1,5W 500mA 180lm 4000K /WW LED 1,5W 500mA 162lm 3000K /XW LED 1,5W 500mA 153lm 2700K
life	> 50.000 h
step MacAdam	3
Indice di Resa Cromatica: Color Rendering Index:	>90
grado IP - IP grade:	65
peso netto - net weight:	0,60 Kg
finiture - finishes:	.33 INOX AISI 316L .33 stainless steel .34 verniciato corten .34 painted corten
alimentatori - drivers:	0127 driver 500mA 1-6 3555 0143/IP driver IP67 500mA 1-7 3555
marcatore: marking:	CE
simboli costruttivi: symbols:	  IP65   

Dimensioni - Dimensions

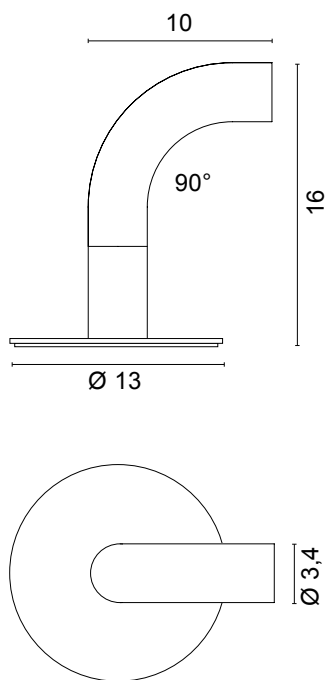

SOLO COLLEGAMENTO IN SERIE - ONLY SERIAL CONNECTION



.33 INOX AISI 316L
stainless steel

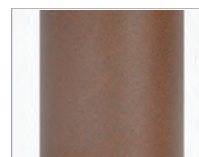

.34 verniciato corten
painted corten

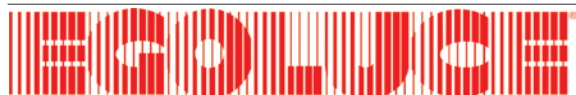

La presente scheda tecnica è di proprietà di EGOLUCE srl. Tutti i diritti sono riservati. Le fotografie, le descrizioni degli apparecchi, i disegni quotati ed i valori fotometrici menzionati sono a titolo indicativo e non costituiscono alcun impegno per la nostra società che si riserva di apportare, in qualsiasi momento e senza preavviso, tutte le modifiche che riterrà opportune.

EGOLUCE s.r.l, via I.Newton 12 - 20016 Pero - Milano
telefono +39 02 339586.1 - fax. +39 02 3535112
e-mail: info@egoluce.com - http://www.egoluce.com